



# IL-VS

## Integrated Leak-Test Vision System





**IL-VS**  
**Leak Detector & Vision**  
**Integrated Unit**

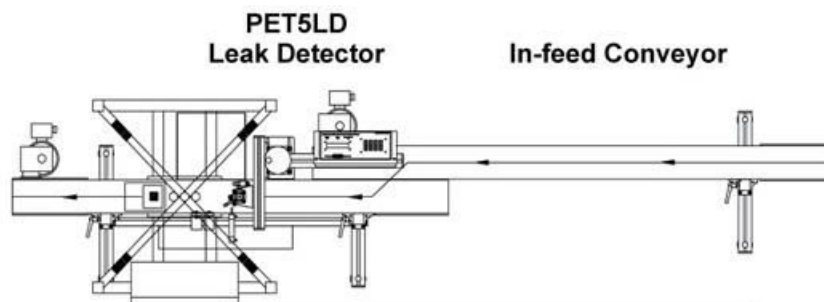

### **Standard Dimensions:**

- **1500 mm length**
- **653 mm width**
- **custom dimensions upon request**

# IL-VS

INTEGRATED LEAK-TEST / VISION SYSTEM



**OPTICAL  
INSPECTION  
PLUS LEAK DETECTOR  
SYSTEM**

**The IL-VS OPTICAL INSPECTION SYSTEM is mounted onto a PET ALL 5 LD High Speed Leak Tester.**



**The Leak Tester detects down to 0.008” holes and defects and ejects the defective container up to speeds of 9000/hour**

## THE OPTICAL INSPECTION SYSTEM

**IL-VS is designed to identify and reject surface defects such as:**

- surface contamination whether resin or foreign material related  $\geq 1$  mm
- wall included contamination whether resin or foreign material related  $\geq 1$  mm
- bottle wall thin spots

**Additional options for inspection characteristics can be added including:**

- colour confirmation
- neck ovality
- neck material interference
- specific neck diameter determinations

**IL-VS includes:**

- high definition cameras with performacne lens
- integrated lighting source
- bottle handling mechanical components specific to application

**Advantages:**

- integrated operator screen allows for control of all inspection criteria
- Simplified interface for operator training and use
- individual bottle setups are stored for use during product change over same as with the LDS
- software is camera resident eliminating the need of complex supervising computers
- password protected to provide system change management
- designed to support ease of additional inspection characterization upgrades
- has network connectivity
- package is assembled in a modular design, software loaded, system tested, crated and shipped with user's instructions

### Four camera 360 Degrees Side Inspection:

- system includes four 640 X 480 resolution Cognex 1100C color cameras
- operator interface in NEMA 4 enclosure contains Cognex Vision View touch screen panel to adjust inspections and monitor results, PLC, I/O module with ethernet connectivity
- mounting structure to support cameras and lighting designed to mount directly to 5LD



**Camera System:  
Close-up showing 4 X 1200  
& LED overhead  
illumination light**



**5th overhead  
camera view showing  
neck**



### One Camera Bottom Inspection (Optional)

- system includes one 640 X 480 resolution Cognex 1100C color camera
- to be connected to existing operator interface
- no interface provided with bottom system
- includes mechanism to support and rotate star wheel including servo motor, drive and controls - this DOES NOT include star wheel - Pet All will provide a flanged surface to mount customer provided wheel
- one 30mm LED Smart Light to illuminate the bottle from the top - camera will be mounted under the bottle and inspecting the bottom outside

## IL-VS OPERATING PARAMETERS:

### Bottle Dimension With Standard Resolution Camera

Maximum Height	127 mm (5.0 in)
Maximum Width	99 mm (3.9 in)
Maximum Length	99 mm (3.9 in)
Neck Diameter	75 mm (2.95 in)
Bottle Diameter	99 mm (3.9 in)

### Machine Dimension With Standard Resolution Camera

Height	1600 mm (63 in)
Length	1500 mm (59 in)
Width	500 mm (11.8 in)
Conveyor Height	1000 mm (39 in)
(custom Feature)	+/-150 mm (5.9 in) adjustment
Bottle Diameter	140 mm (5.5 in)

### Specifications

LD Test Capacity	0.1 - 10 L
Test Rates	≤ 9000 parts per hour
LD Air Requirement	7 Bar (100 psi)
LD Pressure Sampling Rate	15,000 per second - 0.001 KPa

### Connections

Rated Voltage	120 V
Rated Current	16 A

### Inspection Accuracy

Surface Inspection	0.2 mm (0.008 in)
Flash Inspection	0.2 mm (0.008 in)
Neck Inspection	0.2 mm (0.008 in)

### SCREEN IMAGES

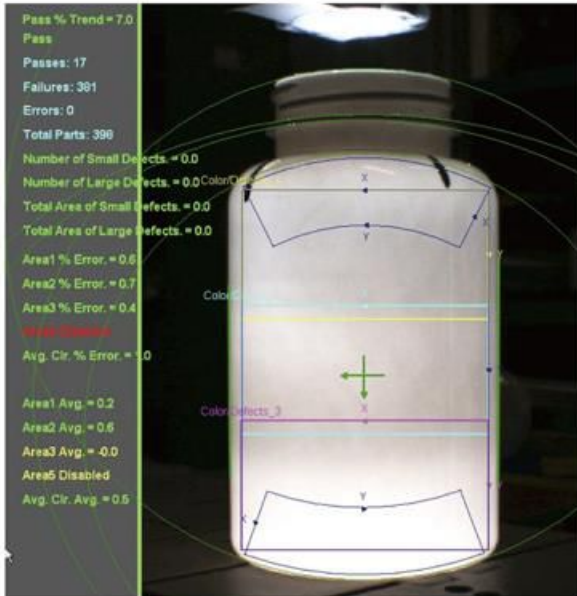

**Close-up showing parameters to be measured for defects**

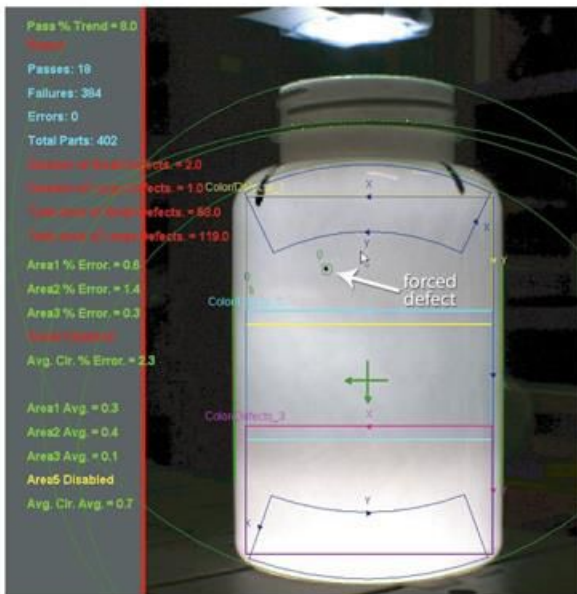

**Close-up showing forced defect**